

High-Speed Drivers with Dual SPST JFET Switches

Features

- Constant On-Resistance Over Entire Analog Range
- Low Leakage
- Low Crosstalk
- Low Hardness

Benefits

- Low Distortion
- Eliminates Large Signal Errors
- High Precision
- High Bandwidth Capability
- Fault Protection

Applications

- Audio Switching
- Video Switching
- Sample/Hold
- Guidance and Control Systems
- Aerospace

Description

The DG180/181/182 are precision dual single-pole, single-throw (SPST) analog switches designed to provide accurate switching of video and audio signals. This series is ideally suited for applications requiring a constant on-resistance over the entire analog range.

The major difference in the devices is the on-resistance (DG180—10 Ω, DG181—30 Ω, DG182—75 Ω). Reduced errors are achieved through low leakage current ($I_{D(on)} < 2$ nA). Applications which benefit from the flat

JFET on-resistance include audio switching, video switching, and data acquisition.

To achieve fast and accurate switch performance, each device comprises four n-channel JFET transistors and a TTL compatible bipolar driver. In the on state, each switch conducts current equally well in either direction. In the off condition, the switches will block up to 20 V peak-to-peak, with feedthrough of less than -60 dB at 10 MHz.

Functional Block Diagram and Pin Configuration

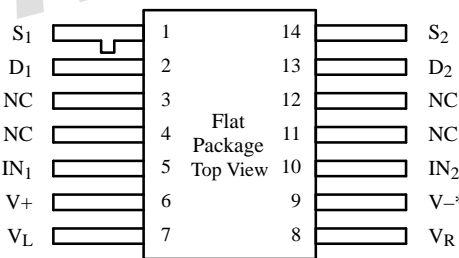
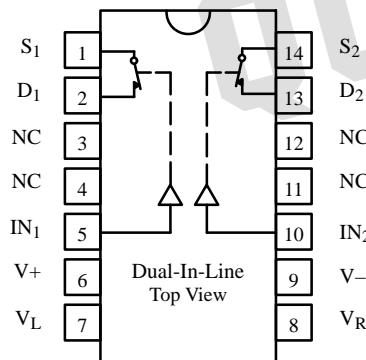

Refer to JAN38510 Information, Military Section

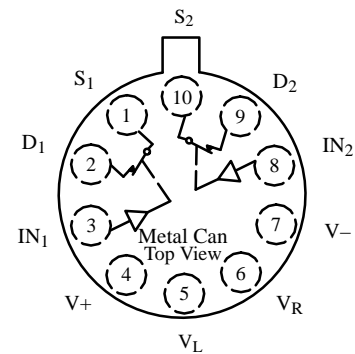

Ordering Information – DG180/181/182

Temp Range	Package	Part Number
-25 to 85°C	10-Pin Metal Can	DG181BA
	14-Pin Sidebrazed	DG180BP
-55 to 125°C	10-Pin Metal Can	DG180AA/883, 5962-8767301IA
		DG181AA/883, JM38510/11101BIA
		DG182AA/883, JM38510/11102BIA
	14-Pin Sidebrazed	DG180AP/883, 5962-8767301CA
		DG181AP/883, JM38510/11101BCA
		DG182AP/883, JM38510/11102BCA
	14-Pin Flat Pack	5962-8767301XA
		JM38510/11101BXA
		JM38510/11102BXA
		JM38510/11102BXA

*Common to Substrate and Case

Truth Table

Logic	Switch
0	ON
1	OFF

Logic "0" ≤ 0.8 V
Logic "1" ≥ 2.0 V

Switches Shown for Logic "0" Input

Updates to this data sheet may be obtained via facsimile by calling Siliconix FaxBack, 1-408-970-5600. Please request FaxBack document #70031.

Absolute Maximum Ratings

V+ to V-	36 V	Current (S or D) DG181, DG182	30 mA
V+ to V _D	33 V	Current (All Other Pins)	30 mA
V _D to V-	33 V	Storage Temperature	-65 to 150°C
V _D to V _D	±22 V	Power Dissipation ^a	
V _L to V-	36 V	10-Pin Metal Can ^b	450 mW
V _L to V _{IN}	8 V	14-Pin Sidebrazed ^c	825 mW
V _L to V _R	8 V	14-Pin Flat Pack ^d	900 mW
V _{IN} to V _R	8 V	Notes:	
V _R to V-	27 V	a. All leads welded or soldered to PC Board.	
V _R to V _{IN}	2 V	b. Derate 6 mW/°C above 75°C	
Current (S or D) DG180	200 mA	c. Derate 11 mW/°C above 75°C	
		d. Derate 10 mW/°C above 75°C	

Specifications^a for DG180

Parameter	Symbol	Test Conditions Unless Otherwise Specified V+ = 15 V, V- = -15 V, V _L = 5 V V _R = 0 V, V _{IN} = 2 V, 0.8 V ^f	Temp ^b	Typ ^c	A Suffix -55 to 125°C		B Suffix -25 to 85°C		Unit	
					Min ^d	Max ^d	Min ^d	Max ^d		
Analog Switch										
Analog Signal Range ^e	V _{ANALOG}		Full		-7.5	15	-7.5	15	V	
Drain-Source On-Resistance	r _{DS(on)}	I _S = -10 mA, V _D = -7.5 V	Room Full	7.5		10 20		15 25	Ω	
Source Off Leakage Current	I _{S(off)}	V _S = ±10 V, V _D = ∓10 V V+ = 10 V, V- = -20 V	Room Hot	0.05		10 1000		15 300	nA	
		V _S = ±7.5 V, V _D = ∓7.5 V	Room Hot	0.05		10 1000		15 300		
Drain Off Leakage Current	I _{D(off)}	V _S = ±10 V, V _D = ∓10 V V+ = 10 V, V- = -20 V	Room Hot	0.04		10 1000		15 300		
		V _S = ±7.5 V, V _D = ∓7.5 V	Room Hot	0.03		10 1000		15 300		
Channel On Leakage Current	I _{D(on)}	V _D = V _S = ±7.5 V	Room Hot	-0.1	-2 -200		-10 -200			
Saturation Drain Current	I _{DSS}	2 ms Pulse Duration	Room	300					mA	
Digital Input										
Input Current with Input Voltage High	I _{INH}	V _{IN} = 5 V	Room Hot	<0.01		10 20		10 20	μA	
Input Current with Input Voltage Low	I _{INL}	V _{IN} = 0 V	Full	-30	-250		-250			
Dynamic Characteristics										
Turn-On Time	t _{on}	See Switching Time Test Circuit	Room	240		400		600	ns	
Turn-Off Time	t _{off}		Room	140		200		250		
Source-Off Capacitance	C _{S(off)}	f = 1 MHz	Room	21					pF	
Drain-Off Capacitance	C _{D(off)}									V _S = -5 V, I _D = 0
Channel-On Capacitance	C _{D(on)}									V _D = -5 V, I _S = 0
Off Isolation	OIRR									V _D = V _S = 0 V
		f = 1 MHz, R _L = 75 Ω	Room	>55					dB	

Specifications^a for DG180

Parameter	Symbol	Test Conditions Unless Otherwise Specified $V_+ = 15\text{ V}$, $V_- = -15\text{ V}$, $V_L = 5\text{ V}$ $V_R = 0\text{ V}$, $V_{IN} = 2\text{ V}$, 0.8 V^f	Temp ^b	Typ ^c	A Suffix -55 to 125°C		B Suffix -25 to 85°C		Unit
					Min ^d	Max ^d	Min ^d	Max ^d	
Power Supplies									
Positive Supply Current	I+	$V_{IN} = 0\text{ V}$, or 5 V	Room	0.6		1.5		1.5	mA
Negative Supply Current	I-		Room	-2.7	-5		-5		
Logic Supply Current	I _L		Room	3		4.5		4.5	
Reference Supply Current	I _R		Room	-1	-2		-2		

Specifications^a for DG181

Parameter	Symbol	Test Conditions Unless Otherwise Specified $V_+ = 15\text{ V}$, $V_- = -15\text{ V}$, $V_L = 5\text{ V}$ $V_R = 0\text{ V}$, $V_{IN} = 2\text{ V}$, 0.8 V^f	Temp ^b	Typ ^c	A Suffix -55 to 125°C		B Suffix -25 to 85°C		Unit
					Min ^d	Max ^d	Min ^d	Max ^d	
Analog Switch									
Analog Signal Range ^e	V _{ANALOG}		Full		-7.5	15	-7.5	15	V
Drain-Source On-Resistance	r _{DS(on)}	I _S = -10 mA, V _D = -7.5 V	Room Full	18		30 60		50 75	Ω
Source Off Leakage Current	I _{S(off)}	V _S = ±10 V, V _D = ∓10 V V ₊ = 10 V, V ₋ = -20 V	Room Hot	0.05		1 100		5 100	nA
		V _S = ±7.5 V, V _D = ∓7.5 V	Room Hot	0.07		1 100		5 100	
Drain Off Leakage Current	I _{D(off)}	V _S = ±10 V, V _D = ∓10 V V ₊ = 10 V, V ₋ = -20 V	Room Hot	0.5		1 100		5 100	
		V _S = ±7.5 V, V _D = ∓7.5 V	Room Hot	0.6		1 100		5 100	
Channel On Leakage Current	I _{D(on)}	V _D = V _S = ±7.5 V	Room Hot	-0.02	-2 -200		-10 -200		
Digital Input									
Input Current with Input Voltage High	I _{INH}	V _{IN} = 5 V	Room Hot	<0.01		10 20		10 20	μA
Input Current with Input Voltage Low	I _{INL}	V _{IN} = 0 V	Full	-30	-250		-250		
Dynamic Characteristics									
Turn-On Time	t _{on}	See Switching Time Test Circuit	Room	85		150		180	ns
Turn-Off Time	t _{off}		Room	95		130		150	
Source-Off Capacitance	C _{S(off)}	f = 1 MHz	Room	9					pF
Drain-Off Capacitance	C _{D(off)}		V _S = -5 V, I _D = 0	Room	6				
Channel-On Capacitance	C _{D(on)}		V _D = -5 V, I _S = 0	Room	14				
Off Isolation	OIRR		V _D = V _S = 0 V	Room	>50				

Specifications^a for DG181

Parameter	Symbol	Test Conditions Unless Otherwise Specified $V_+ = 15\text{ V}$, $V_- = -15\text{ V}$, $V_L = 5\text{ V}$ $V_R = 0\text{ V}$, $V_{IN} = 2\text{ V}$, 0.8 V^f	Temp ^b	Typ ^c	A Suffix -55 to 125°C		B Suffix -25 to 85°C		Unit
					Min ^d	Max ^d	Min ^d	Max ^d	
Power Supplies									
Positive Supply Current	I ⁺	$V_{IN} = 0\text{ V}$, or 5 V	Room	0.6		1.5		1.5	mA
Negative Supply Current	I ⁻		Room	-2.7	-5		-5		
Logic Supply Current	I _L		Room	3.1		4.5		4.5	
Reference Supply Current	I _R		Room	-1	-2		-2		

Specifications^a for DG182

Parameter	Symbol	Test Conditions Unless Otherwise Specified $V_+ = 15\text{ V}$, $V_- = -15\text{ V}$, $V_L = 5\text{ V}$ $V_R = 0\text{ V}$, $V_{IN} = 2\text{ V}$, 0.8 V^f	Temp ^b	Typ ^c	A Suffix -55 to 125°C		B Suffix -25 to 85°C		Unit
					Min ^d	Max ^d	Min ^d	Max ^d	
Analog Switch									
Analog Signal Range ^e	V _{ANALOG}		Full		-10	15	-10	15	V
Drain-Source On-Resistance	r _{DS(on)}	$I_S = -10\text{ mA}$, $V_D = -7.5\text{ V}$	Room Full	35		75 150		100 150	Ω
Source Off Leakage Current	I _{S(off)}	$V_S = \pm 10\text{ V}$, $V_D = \mp 10\text{ V}$ $V_+ = 10\text{ V}$, $V_- = -20\text{ V}$	Room Hot	0.05		1 100		5 100	nA
		$V_S = \pm 10\text{ V}$, $V_D = \mp 10\text{ V}$	Room Hot	0.07		1 100		5 100	
Drain Off Leakage Current	I _{D(off)}	$V_S = \pm 10\text{ V}$, $V_D = \mp 10\text{ V}$ $V_+ = 10\text{ V}$, $V_- = -20\text{ V}$	Room Hot	0.4		1 100		5 100	
		$V_S = \pm 10\text{ V}$, $V_D = \mp 10\text{ V}$	Room Hot	0.5		1 100		5 100	
Channel On Leakage Current	I _{D(on)}	$V_D = V_S = \pm 10\text{ V}$	Room Hot	-0.02	-2 -200		-10 -200		
Digital Input									
Input Current with Input Voltage High	I _{INH}	$V_{IN} = 5\text{ V}$	Room Hot	<0.01		10 20		10 20	μA
Input Current with Input Voltage Low	I _{INL}	$V_{IN} = 0\text{ V}$	Full	-30	-250		-250		
Dynamic Characteristics									
Turn-On Time	t _{on}	See Switching Time Test Circuit	Room	120		250		300	ns
Turn-Off Time	t _{off}		Room	100		130		150	
Source-Off Capacitance	C _{S(off)}	f = 1 MHz	Room	9					pF
Drain-Off Capacitance	C _{D(off)}		$V_S = -5\text{ V}$, $I_D = 0$	Room	6				
Channel-On Capacitance	C _{D(on)}		$V_D = -5\text{ V}$, $I_S = 0$	Room	14				
Off Isolation	OIRR	f = 1 MHz, R _L = 75 Ω	Room	>50					dB

Specifications^a for DG182

Parameter	Symbol	Test Conditions Unless Otherwise Specified $V_+ = 15\text{ V}$, $V_- = -15\text{ V}$, $V_L = 5\text{ V}$ $V_R = 0\text{ V}$, $V_{IN} = 2\text{ V}$, 0.8 V^f	Temp ^b	Typ ^c	A Suffix -55 to 125°C		B Suffix -25 to 85°C		Unit
					Min ^d	Max ^d	Min ^d	Max ^d	
Power Supplies									
Positive Supply Current	I_+	$V_{IN} = 0\text{ V}$, or 5 V	Room	0.6		1.5		1.5	mA
Negative Supply Current	I_-		Room	-2.7	-5		-5		
Logic Supply Current	I_L		Room	3.1		4.5		4.5	
Reference Supply Current	I_R		Room	-1	-2		-2		

Notes:

- Refer to PROCESS OPTION FLOWCHART (Section 5 of the 1994 Data Book or FaxBack number 7103).
- Room = 25°C, Full = as determined by the operating temperature suffix.
- Typical values are for DESIGN AID ONLY, not guaranteed nor subject to production testing.
- The algebraic convention whereby the most negative value is a minimum and the most positive a maximum, is used in this data sheet.
- Guaranteed by design, not subject to production test.
- V_{IN} = input voltage to perform proper function.

Schematic Diagram (Typical Channel)

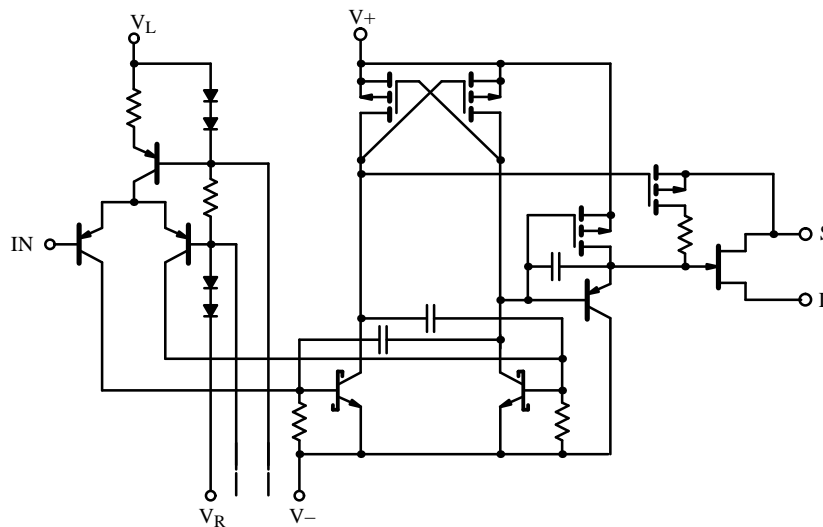

Figure 1.

Test Circuits

Feedthrough due to charge injection may result in spikes at the leading and trailing edge of the output waveform.

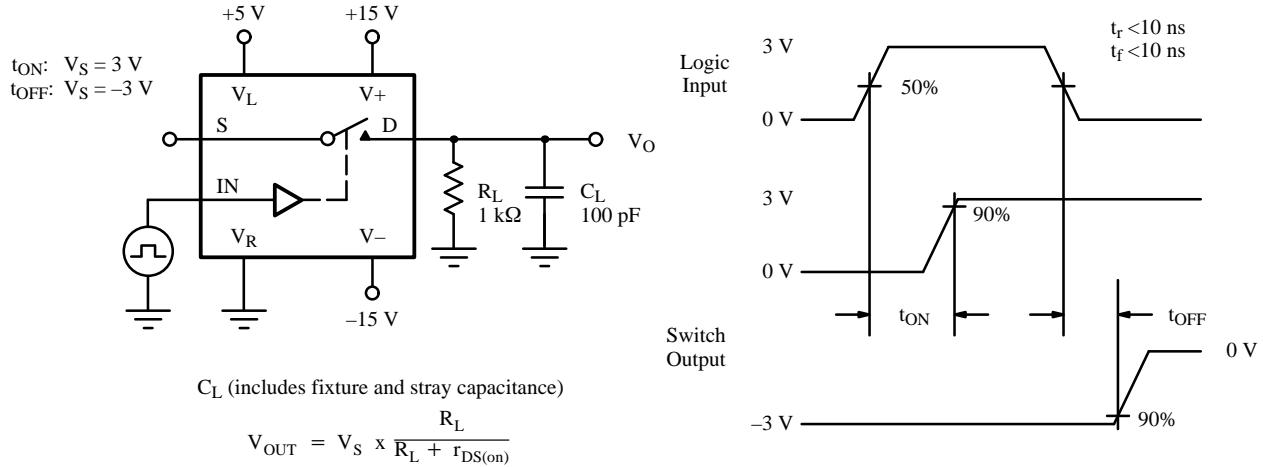

Figure 2. Switching Time

Application Hints^a

Switch	V+ Positive Supply Voltage (V)	V- Negative Supply Voltage (V)	VL Logic Supply Voltage (V)	VR Reference Sup- ply Voltage (V)	VIN Logic Input Voltage VINH(min)/ VINL(max) (V)	VS Analog Voltage Range (V)
DG180 DG181	15 ^b	-15	5	GND	2.0/0.8	-7.5 to 15
	10	-20	5	GND	2.0/0.8	-12.5 to 10
	12	-12	5	GND	2.0/0.8	-4.5 to 12
DG182	15 ^b	-15	5	GND	2.0/0.8	-10 to 15
	10	-20	5	GND	2.0/0.8	-15 to 10
	12	-12	5	GND	2.0/0.8	-7 to 12

Notes:

- Application Hints are for DESIGN AID ONLY, not guaranteed and not subject to production testing.
- Electrical Parameter Chart based on V+ = 15 V, VL = 5 V, VR = GND

Typical Characteristics

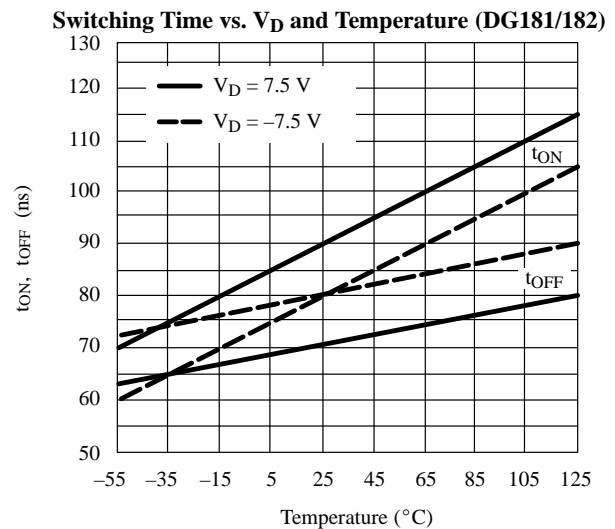
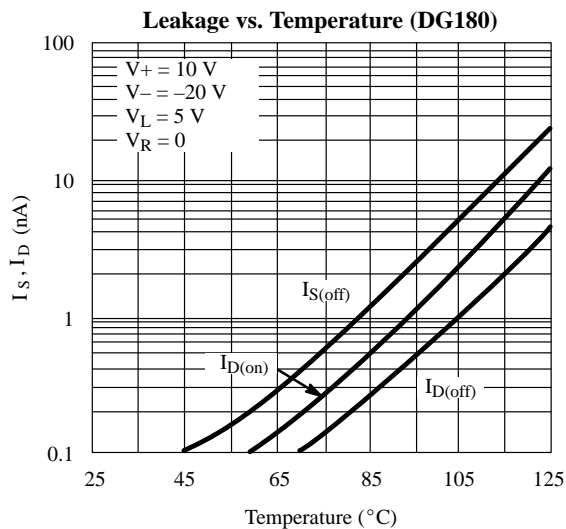
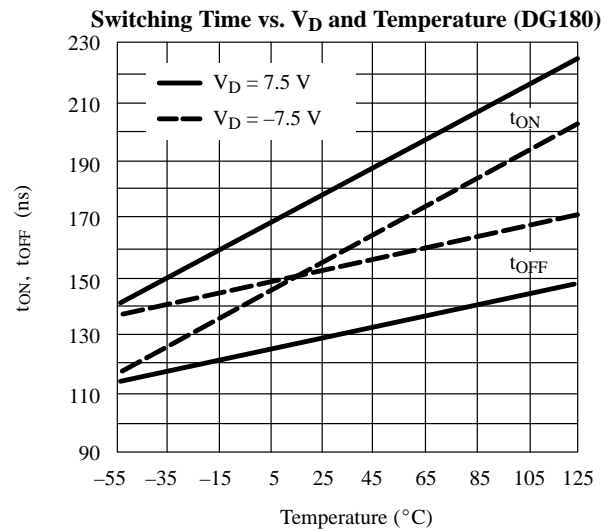
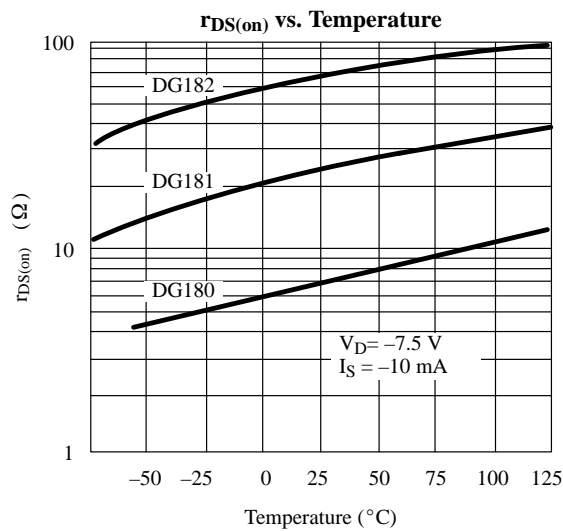
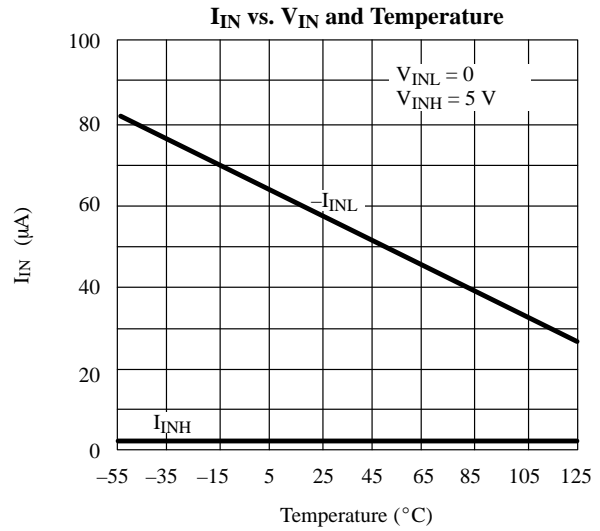
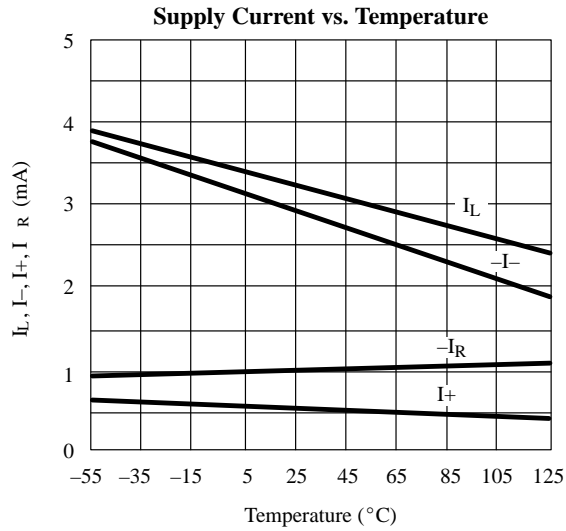

Typical Characteristics (Cont'd)

$I_{D(off)}$ vs. Temperature (DG181/182)

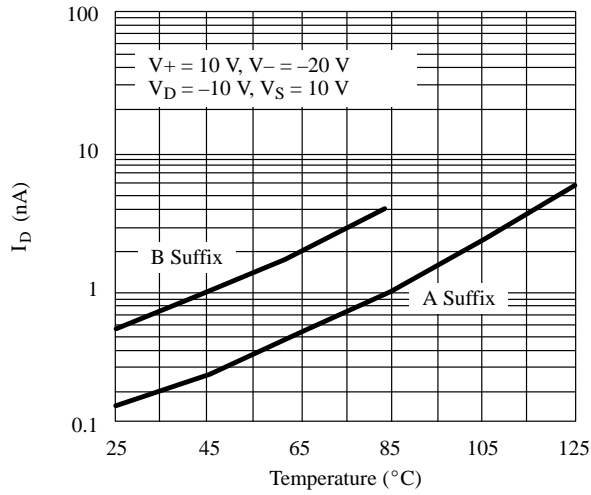

Capacitance vs. V_D or V_S (DG180)

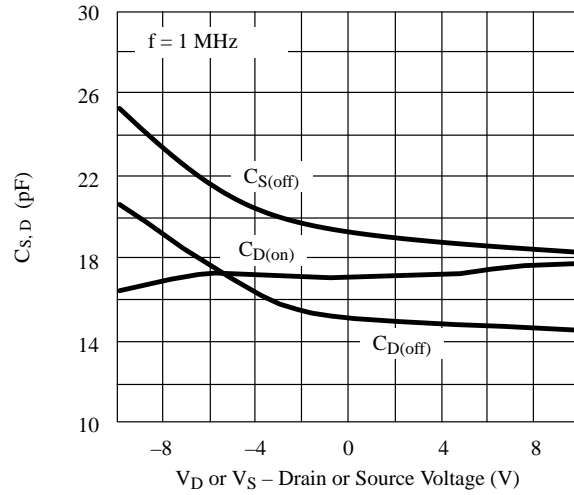

Capacitance vs. V_D or V_S (DG181/182)

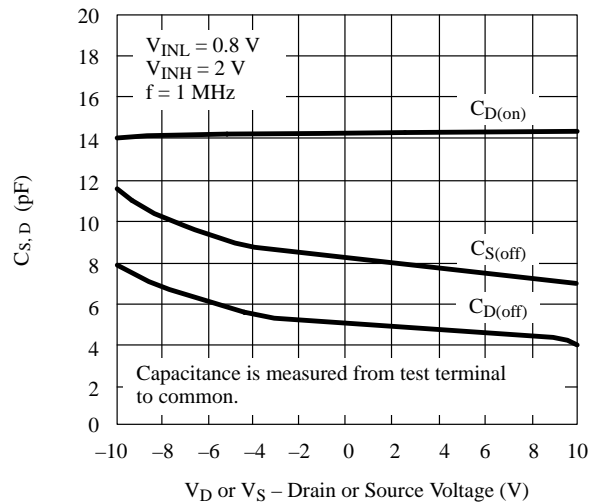

Off Isolation vs. Frequency

